

# D 406

- 6 membrane semidrauliche, collettori esterni, comando disponibile solo a distanza, parti a contatto coi liquidi in materiale anticorrosivo
- 6 diaphragms semi-hydraulic, external manifolds, control assembly remote only, all wetted parts are in corrosion resistant materials
- 6 membranas semihidráulicas, colectores externos, partes en contacto con líquidos en material anticorrosión. Mando a distancia
- 6 membranes semi-hydrauliques, collecteurs à l'extérieur du carter. Groupe de commande seulement à distance. Parties en contact avec le liquide en matériel anticorrosif
- Pumpe in Sternbauweise mit 6 Kolben-Membranen halbhydraulisch gestützt. Aussen liegende Saug-Druckkanäle und für Fernbedienungsarmatur vorgesehen. Flüssigkeitsführende Teile aus rostbeständigem Material

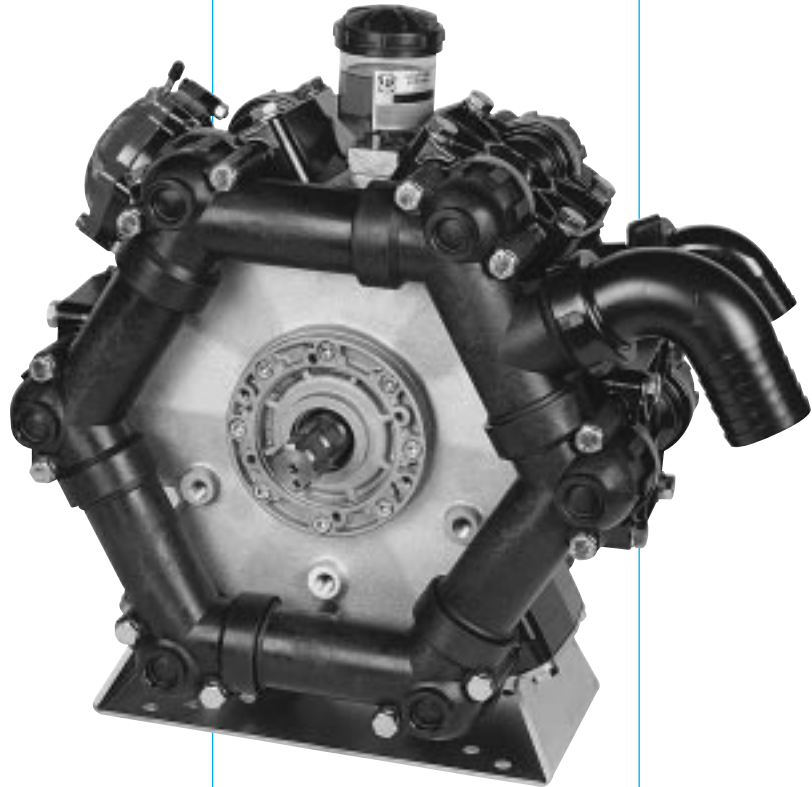

**IMPIEGHI**  
Diserbo e concimazione liquida

**APPLICATIONS**  
Row-crops spraying, liquid fertilizing

**APLICACIONES**  
Equipos herbicidas y abono líquido

**EMPLOIS**  
Désherbage et engrais liquides

**VERWENDUNGEN**  
Feldspritzgeräte, flüssige Düngung

COMPONENTI	MATERIALI	COMPONENTS	MATERIALS	COMPONENTES	MATERIALES	COMPOSANTS	MATERIAUX	TEILE	MATERIALEN
carter	alluminio	pump body	aluminium	cuerpo bomba	aluminio	carter	aluminium	Gehäuse	Aluminium
testata	alluminio plastificato	pump head	plastic coated aluminium	culata	aluminio plastificado	culasse	aluminium plastifié	Zylinderkopf	kunststoffüberzogenes Alumin.
collettori	resina rinforzata	manifolds	reinforced resin	colectores	resina reforzada	clavatures	resine renforcée	Saug-Druckkanälen	verstärkt Kunstharz
valvola a.-m.	acciaio inox	check valve	stainless steel	válvula a.- m.	acero inox	clapet asp.ref.	acier inox	Ventil	rostfreier Stahl
cappello/valvola	resina sintetica	valve cage	synthetic resin	cajera válvula	resina sintética	cage du clapet	resine synthétique	Ventilkäfig	Kunstharz
membrana	*gomma nitrilica	pump diaphragm	*nitril rubber	membrana	*goma nitrilica	membrane	*caoutchouc nitrilique	Membrane	*Gummi
camera aria	*gomma nitrilica	dumper diaphragm	*nitril rubber	membrana calderín	*goma nitrilica	chambre à air	*caoutchouc nitrilique	Windkessel-membrane	*Gummi
albero	acciaio cement. e temperato	pump shaft	casehardened steel	cingüeñal	acero cement. y templado	vilebrequin	acier cementé et trempé	Kurbelwelle	gehärteter Stahl

\* Optional Desmopan

Giri/ 1': max 550  
Pressione: max 20 bar  
Portata: max 403 ℓ/1'  
Peso: Kg 51,5  
Max disl. asp.: m 1

Max RPM: 550  
Pressure: max 20 bar  
Capacity: max 403 ℓ/1'  
Weight: Kg 51,5  
Max suction lift: m 1

RPM max: 550  
Presión: max 20 bar  
Caudal: max 403 ℓ/1'  
Peso: Kg 51,5  
Max disn. asp.: m 1

Tours / 1': max 550  
Pression: max 20 bar  
Débit: max 403 ℓ/1'  
Poids: Kg 51,5  
Max haut. asp.: m 1

Umdr.Pro Minute: max 550  
Druck: max 20 bar  
Kapazität: max 403 ℓ/1'  
Gewicht: Kg 51,5  
Max Ansaughöhe: m 1

# D 406

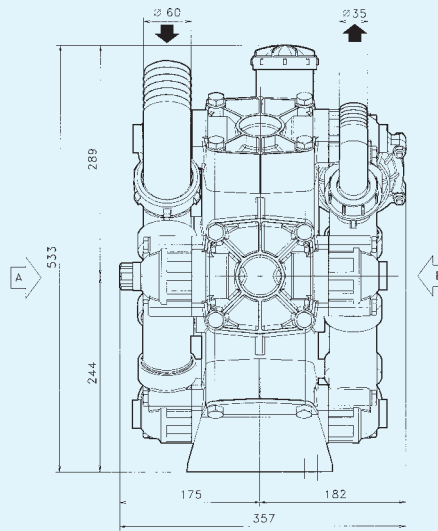
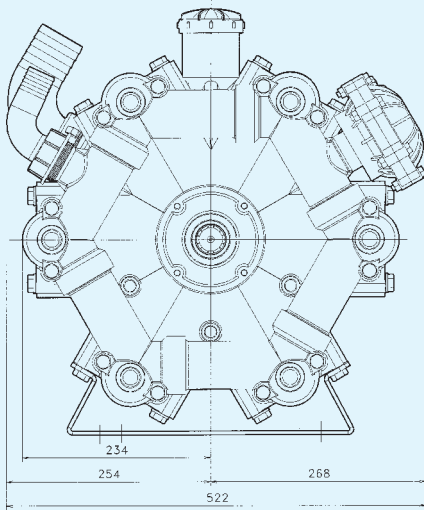

VISTA BASE POMPA

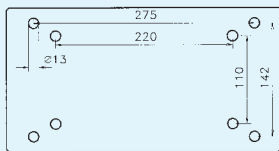

VISTA da A

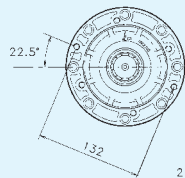

2 fori M10x14

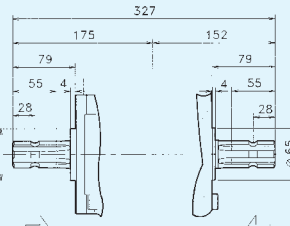

VISTA da B

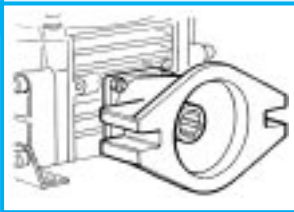
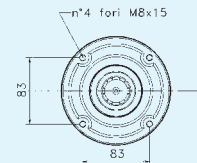

Kit flangiatura motore idraulico lato B

Adapter flange kit for hydraulic motor side B

Brida para motores hidráulicos lado B

Bride pour moteur hydraulique coté B

Geflanscht zu Hydromotoren Seite B

## VERSIONI

Albero passante M 1"3/8  
M 1"3/8. Possibile applicazione di pompa idraulica lato B

## VERSIONS

Through shaft M 1"3/8  
M 1"3/8. Possible application of ancillary hydraulic pump side B

## VERSIONES

Eje estriado estriado M 1"3/8  
M 1"3/8. Posible aplicación de bomba hidráulica auxiliar lado B

## VERSIONS

Arbre traversant cannelé mâle  
1"3/8. Possible application de pompe hydraulique auxiliaire coté B

## AUSFÜHRUNGEN

Durchgehende Welle mit 1"3/8  
Gelenkwellenprofil. Mögliche Anwendung mit hydraulischer Hilfspumpe Seite B

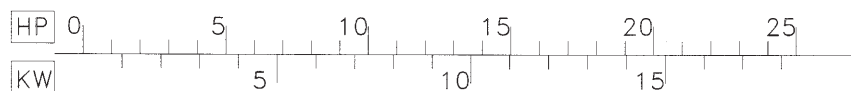
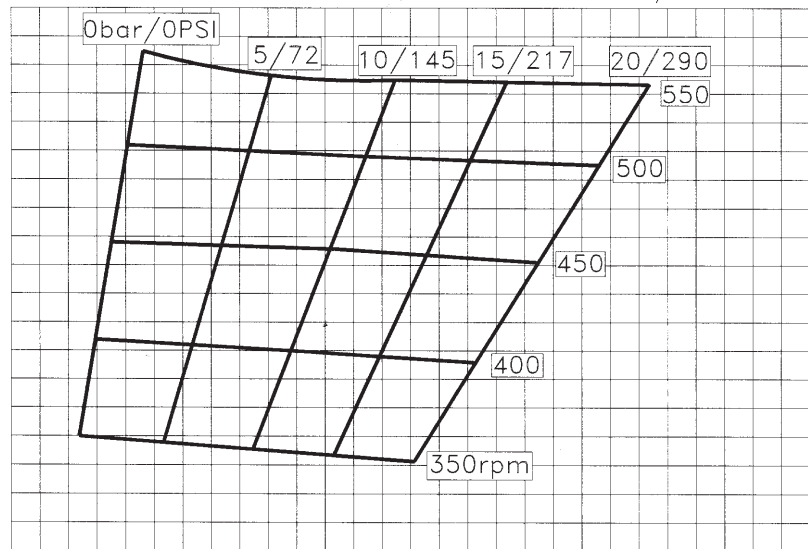
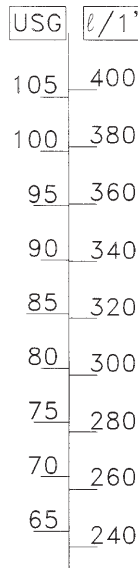

# imovilli pompe S.r.l.

Via Masaccio, 1 Zona Industriale Mancasale - 42010 Reggio Emilia Italy Tel. +39 0522 516595 Fax +39 0522 514735  
www.imovillipompe.it • e-mail: info@imovillipompe.it